

版本	变更内容	工程确认	日期

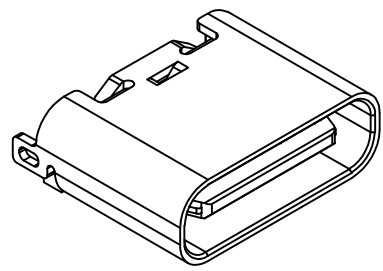

- TYPE C USB技术要求:
- 电气性能
    - 1.1 额定电流 3A/5A.
    - 1.2 额定电压: 5V.
    - 1.3 耐压: 500 V(AC) for 1 min.
    - 1.4 绝缘阻抗: 100 MΩ Min.
  - 机械性能
    - 2.1 插入力: 5-20N. 拔出力: 6-20N.
    - 2.2 寿命测试: 5000/10000cycles Max.
    - 2.3 推力: 50N min.
    - 2.4 剥离强度: 150N min.
    - 2.5 扭曲强度: 0.75Nm
  - 材料要求
    - 4.1 胶芯材料: LCP/PA9T
    - 4.2 外壳材料: SPCC/C2680/SUS304
    - 4.3 端子材料: C2680/C5191/C7025
  - 盐雾要求: 24H/48H
  - 工作温度: -20° C~85° C

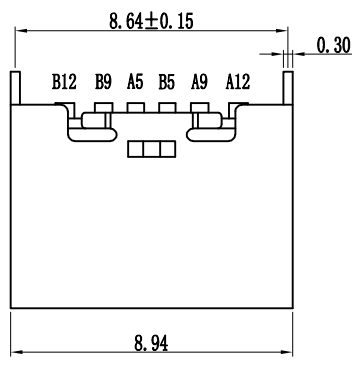
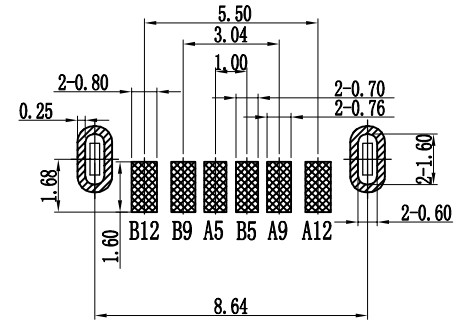
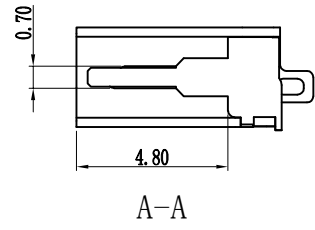
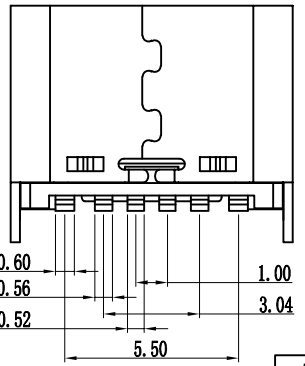
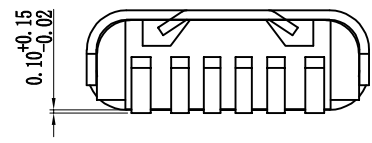
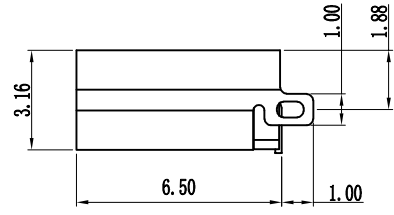
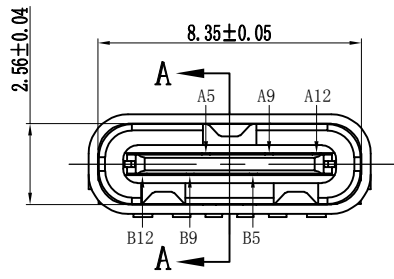

PCB板参考图

A5	CC1	B12	GND
A9	VBUS	B9	VBUS
A12	GND	B5	CC2
PIN	SIGNAL NAME	PIN	SIGNAL NAME

一般公差加工参考表	
X. ±	X. ± 2'
.XX ±0.25	.XX ± 1'
.XX ±0.15	.XX ± 0.5'
.XXX ±0.05	.XXX ± 0.1'
⌀	MM 比例

公司名称		0755-29965558 0755-29165819	
设计	周建明	品名	Type C 母座 6P 立式 贴片 H=6.5
审核	李知民	图号	6P 立贴 H=6.5
核准	李伟	版本	A
		页码	